

OC6 ST

Cold Space Merchandiser® Counter-Height

Project Name: _____

Item #: _____ Quantity: _____



Width*	Depth**	Height***	Shelves	Cold Space™	Ship Weight	Ship Cube	Cooling Capacity	Electrical
20 1/2" 520 mm	28" 712 mm	36" 913 mm	2	6.1	130 lbs 59 kg	18 cu. ft 0.51 m³	1/6 HP	115V/1.9 Amp/60 Hz - Single Phase - NEMA 5-15P, Dedicated Circuit

*** Add 1/2" (12mm) for Threaded-In Levelers. Millimeters rounded up.

Shipped less Graphics. Custom Graphics Optional.

Flat Shelf 20 oz /600ml		Gravity GlideSet™ 20 oz /600ml		Trailerload Quantity (53')
Packout	Facings	Packout	Facings	
96	6	-	-	162

Premium Features



Hybricold™ Refrigeration

 Finless Free&Clear™
Condenser Coil

 Automatic Stainless Steel
Condensate Control System

Priority Air-Flow



LED Lighting System

 HABCO
Insulated Glass

OC6 ST: Designed to enhance refrigerated merchandising in-counter, with counter-height reinforced stainless steel top.

Refrigeration:

- Traditional non-removable, split forced-air refrigeration system employs R-134a refrigerant within a sealed capillary tube system.
- Condensing unit is rear-mounted and is easily accessed for ease of maintenance.
- Designed to hold 33°F to 38°F (0.5°C to 3.3°C).
- HYBRICOLD™ Refrigeration Design requires less space, thus allowing optimized internal storage and merchandising within a small footprint.
- Slim Profile Heat Exchange provides Maximum Cold Space™ in the smallest of footprints.
- Priority, channelled air flow provides optimum cooling and energy efficiency within cabinet and exclusively at rear of unit to save space and optimize heat exchange ventilation.
- Finless, Free&Clear™ Condenser Coil maximizes air-flow over the compressor, reduces energy consumption and is non-clogging.
- Automatic, stainless steel condensate control system.
- Quality, self-lubricating and sealed motors with streamlined air-flow provide quieter yet robust refrigeration.

Cabinet:

- Exterior – durable textured black with stainless steel top.
- Interior – NSF approved white aluminum liner with stainless steel floor.
- Insulation – cabinet is foamed-in-place with eco-conscious, polyurethane insulation.
- Heavy duty thread-in leveler legs.

Doors:

- Self-Closing Swing Door features hold-open position and are reversible on-location.
- Magnetic gaskets are single piece bead-mount construction easily removable for cleaning.
- Heat Reflecting HABCO Insulated Safety Glass with black extruded frame.
- Durable, external door handle(s).

Lighting:

- LED Lighting System for Brilliant Illuminated Interior Display and Available Backlit Door Merchandising, on Switch.

Storage:

- Two (2) white coated shelves 17 1/16"W x 17 5/8"D (434mm x 448mm), are NSF approved.
- Heavy duty aluminum shelving pilasters will not peel or chip adjustment of 1/2" (13mm) increments.

Electrical:

- Factory power cord installed for connection to a sole-use (dedicated) 115V/60Hz/1-Phase, 15 Amp circuit.

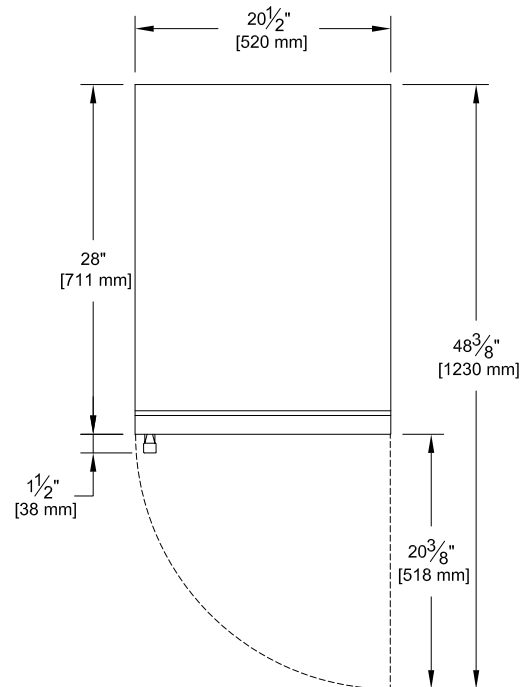
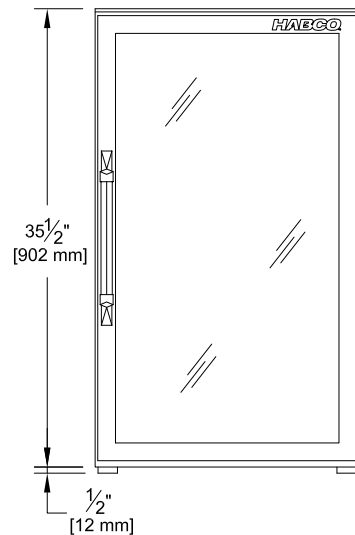

HABCO MANUFACTURING INC. 501 GORDON BAKER ROAD, TORONTO, ONTARIO, CANADA, M2H 2S6
Toll Free CAN: 1-800-387-5398 USA: 1-800-448-0244 Fax: 416-491-6982 www.habcomfg.com